

HG系列重负荷型滚珠直线导轨
HG Series Heavy Load Ball Type

HG系列直线导轨尺寸表
Dimensions for HXHV HG Series

(1) HGH-CA/HGH-HA

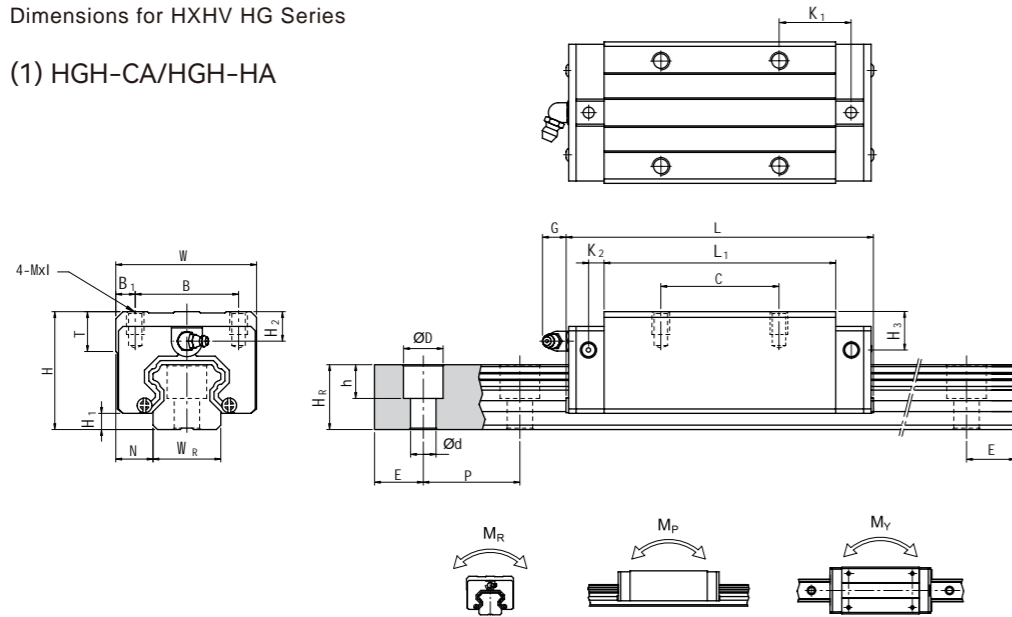

型号 Model No.	组件尺寸 Dimensions of Assembly (mm)			滑块尺寸 Dimensions of Block (mm)													导轨尺寸 Dimensions of Rail (mm)						导轨的 固定螺栓尺寸 Mounting Bolt for Rail (mm)	基本 动额定负荷 Basic Dynamic Load Rating C(kN)	基本 静额定负荷 Basic Static Load Rating C ₀ (kN)	容许静力矩 Static Rated Moment			重量 Weight		
	H	H ₁	N	W	B	B ₁	C	L ₁	L	K ₁	K ₂	G	MXI	T	H ₂	H ₃	W _R	H _R	D	h	d	P				E	M _R	M _P	M _Y	滑块 Block Kg	导轨 Rail Kg/m
HGH 15CA	28	4.3	9.5	34	26	4	26	39.4	61.4	10	4.85	5.3	M4x4	6	3.95	3.7	15	15	7.5	5.3	4.5	60	20	M4x16	14.7	23.47	0.12	0.10	0.10	0.18	1.45
HGH 20CA	30	4.6	12	44	32	6	36	50.5	77.5	12.25	6	12	M5x6	8	6	6	20	17.5	9.5	8.5	6	60	20	M5x16	27.1	36.68	0.27	0.20	0.20	0.30	2.21
HGH 20HA																									32.7	47.96	0.35	0.35	0.35	0.39	
HGH 25CA	40	5.5	12.5	48	35	6.5	35	58	84	15.7	6	12	M6x8	8	10	9	23	22	11	9	7	60	20	M6x20	34.9	52.82	0.42	0.33	0.33	0.51	3.21
HGH 25HA																									42.2	69.07	0.56	0.57	0.57	0.69	
HGH 30CA	45	6	16	60	40	10	40	70	97.4	20.25	6	12	M8x10	8.5	9.5	13.8	28	26	14	12	9	80	20	M8x25	48.5	71.87	0.66	0.53	0.53	0.88	4.47
HGH 30HA																									58.6	93.99	0.88	0.92	0.92	1.16	
HGH 35CA	55	7.5	18	70	50	10	50	80	112.4	20.6	7	12	M8x12	10.2	16	19.6	34	29	14	12	9	80	20	M8x25	64.6	93.88	1.16	0.81	0.81	1.14	6.30
HGH 35HA																									77.9	122.77	1.54	1.40	1.40	1.92	
HGH 45CA	70	9.5	20.5	86	60	13	60	97	139.4	23	10	12.9	M10x17	16	18.5	30.5	45	38	20	17	14	105	22.5	M12x35	103.8	146.71	1.98	1.55	1.55	2.73	10.41
HGH 45HA																									125.3	191.85	2.63	2.68	2.68	3.61	
HGH 55CA	80	13	23.5	100	75	12.5	75	117.7	166.7	27.35	11	12.9	M12x18	17.5	22	29	53	44	23	20	16	120	30	M14x45	153.2	211.23	3.69	2.64	2.64	4.17	15.08
HGH 55HA																									184.9	276.23	4.88	4.57	4.57	5.49	
HGH 65CA	90	15	31.5	126	76	25	70	144.2	200.2	43.1	14	12.9	M16x20	25	15	15	63	53	26	22	18	150	35	M16x50	213.2	287.48	6.65	4.27	4.27	7.00	21.18
HGH 65HA																									277.8	420.17	9.38	7.38	7.38	9.82	

注:1kgf=9.81N Note:1kgf=9.81N

(2) HGL-CA/HGL-HA

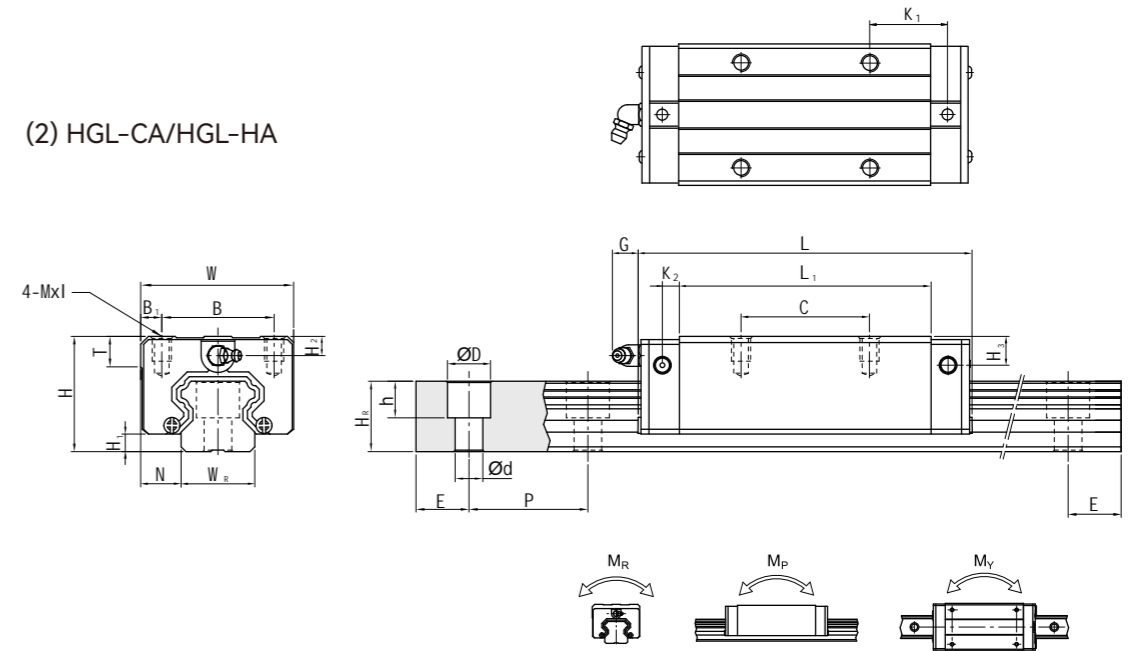

型号 Model No.	组件尺寸 Dimensions of Assembly (mm)			滑块尺寸 Dimensions of Block (mm)													导轨尺寸 Dimensions of Rail (mm)						导轨的 固定螺栓尺寸 Mounting Bolt for Rail (mm)	基本 动额定负荷 Basic Dynamic Load Rating C(kN)	基本 静额定负荷 Basic Static Load Rating C ₀ (kN)	容许静力矩 Static Rated Moment			重量 Weight		
	H	H ₁	N	W	B	B ₁	C	L ₁	L	K ₁	K ₂	G	MXI	T	H ₂	H ₃	W _R	H _R	D	h	d	P				E	M _R	M _P	M _Y	滑块 Block Kg	导轨 Rail Kg/m
HGL 15CA	24	4.3	9.5	34	26	4	26	39.4	61.4	10	4.85	5.3	M4x4	6	3.95	3.7	15	15	7.5	5.3	4.5	60	20	M4x16	14.7	23.47	0.12	0.10	0.10	0.14	1.45
HGL 25CA	36	5.5	12.5	48	35	6.5	35	58	84	15.7	6	12	M6x6	8	6	5	23	22	11	9	7	60	20	M6x20	34.9	52.82	0.42	0.33	0.33	0.42	3.21
HGL 25HA																									42.2	69.07	0.56	0.57	0.57	0.57	
HGL 30CA	42	6	16	60	40	10	40	70	97.4	20.25	6	12	M8x10	8.5	6.5	10.8	28	26	14	12	9	80	20	M8x25	48.5	71.87	0.66	0.53	0.53	0.78	4.47
HGL 30HA																									58.6	93.99	0.88	0.92	0.92	1.03	
HGL 35CA	48	7.5	18	70	50	10	50	80	112.4	20.6	7	12	M8x12	10.2	9	12.6	34	29	14	12	9	80	20	M8x25	64.6	93.88	1.16	0.81	0.81	1.14	6.30
HGL 35HA																									77.9	122.77	1.54	1.40	1.40	1.52	
HGL 45CA	60	9.5	20.5	86	60	13	60	97	139.4	23	10	12.9	M10x17	16	8.5	20.5	45	38	20	17	14	105	22.5	M12x35	103.8	146.71	1.98	1.55	1.55	2.08	10.41
HGL 45HA																									125.3	191.85	2.63	2.68	2.68	2.75	
HGL 55CA	70	13	23.5	100	75	12.5	75	117.7	166.7	27.35	11	12.9	M12x18	17.5	12	19	53	44	23	20	16	120	30	M14x45	153.2	211.23	3.69	2.64	2.64	3.25	15.08
HGL 55HA																									184.9	276.23	4.88	4.57	4.57	4.27	

注:1kgf=9.81N Note:1kgf=9.81N